

# **OL 4503**

## **Oil-Air Cooling Unit**

Specification and User Manual



[www.tark-solutions.com](http://www.tark-solutions.com)

Any information furnished by Tark Thermal Solutions and its agents, whether in specifications, data sheets, product catalogues or otherwise, is believed to be (but is not warranted as being) accurate and reliable, is provided for information only and does not form part of any contract with Tark Thermal Solutions. All specifications are subject to change without notice. Tark Thermal Solutions assumes no responsibility and disclaims all liability for losses or damages resulting from use of or reliance on this information. All Tark Thermal Solutions products are sold subject to the Tark Thermal Solutions Terms and Conditions of sale (including Tark Thermal Solutions limited warranty) in effect from time to time, a copy of which will be furnished upon request.

© Copyright 2025 Tark Thermal Solutions. All rights reserved.

# Table of Contents

<b>1. About this Manual</b>	<b>6</b>
1.1 Terms of Guarantee	6
1.2 Contact Information	7
<b>2. Product Identification</b>	<b>8</b>
2.1 Unit Specifications	8
2.2 Identification Plate	8
<b>3. Safety Regulations</b>	<b>9</b>
3.1 Hazard classes	9
3.2 Safety Symbols	9
3.3 Hints for Safe Operation	10
3.4 Prevent Hazards	10
3.5 Hints Regarding the Electrical Equipment	10
3.6 Environmental Issues	11
3.7 Protective Clothing	11
3.8 Safety Equipment	11
3.9 Safety and Signaling Equipment included in the Unit	11
3.10 Guards	12
3.11 Caution Labels	13
3.12 In Case of Accidents	13
<b>4. Product Description</b>	<b>14</b>
4.1 Intended Use	14
4.2 Use not in Conformance with the Intended Use	14
4.3 Unit Components	15
4.4 Cooling Circuit	15
4.5 Specifications	16
4.6 Setting-up Requirements	17
4.7 Infrastructure	17
<b>5. Transport</b>	<b>18</b>
5.1 Safety Indications for Transportation and Setting-up	18
5.2 Transportation of the Unit	18
5.3 Unpacking	18
<b>6. Initial Operation</b>	<b>19</b>
6.1 Safety Indications Related to Initial Operation	19
6.2 Setting to Work	19
6.3 Cooling Circuit Connection and Filling	20

6.4 Electrical Connections	22
6.5 Carrying out Setting to Work	22
6.6 Daily Start-up	23
6.7 Setting to work after Storage	23
<b>7. Controlling the Unit</b>	<b>24</b>
7.1 Safety Indications for Controlling the Unit	24
7.2 Switching on the Unit	24
7.3 Switching off the Unit	24
7.4 Settings	25
7.5 Pressure Setting on the Angle-type Safety Valve	25
7.6 Setting the Thermostat	26
<b>8. Disruptions</b>	<b>27</b>
8.1 Disruption in Operation	27
8.2 Trouble Shooting	27
<b>9. Maintenance and Cleaning</b>	<b>28</b>
9.1 Maintenance Schedule	28
9.2 Cleaning of Heat Exchanger	28
9.3 Refilling of Coolant	28
9.4 Cleaning of Unit Casing	28
<b>10. Repair</b>	<b>29</b>
<b>11. Dismounting, Disposal, Storage</b>	<b>30</b>
11.1 Temporary Placing out of Operation	30
11.2 Re-packaging of the unit	30
11.3 Storing the Unit	30
11.4 Disposal	30
11.5 Disposal of Operating Materials	31
11.6 Return of the unit to Tark Thermal Solutions	31
<b>12. Wear Parts and Spare Parts</b>	<b>32</b>
<b>13. Addendum</b>	<b>34</b>
Performance Chart	34
Flow Scheme	35
Wiring Diagram	36

## Revision History

Rev	Date	Description	Name	Page
1.0	29-Nov-13	First version	Edom / Pfeiffer	
2.0	06-Jul-15	Spare part numbers changed	Dany / Bitenaite	p. 33
3.0	29-jun-17	Updated format	H. Sharef	All
3.1	24-apr-18	Updated safety valve	A. Wolf	p. 25, 34
3.2	07-Jun-19	Pump capacity changed	O. Lundqvist	p.16
3.3	04-Sep-20	Specs. for Shell Diala updated to S4 from S3	A. Olsson	p.16
3.4	25-Feb-2021	Replaced 95205237.00 with 2066.00	A. Kim	p. 34
3.5	7-Jul-2021	Reformatted manual to LTS Template	M. Maria	
3.6	9-Feb-2023	Updated wiring diagram (EO2346)	B. Kabasa	p. 36
3.7	14-Nov-2024	Update of spare part list	S. El Fadali	p. 33
3.8	5-May-2025	Released as Tark Thermal Solutions	N. Hult	All

# 1. About this Manual

This document is the English translation of the original Operation Manual in German language for the Oil-Air Cooling Unit OL 4503 (called unit in the following). It is based on German safety regulations. In your country other regulations may apply.

This Operational Manual addresses the needs of the user of the unit. Its intention is to allow the safe operation of the unit. Thus, it should be read carefully and be kept in a space accessible for the users of the unit at any time.

All chapters of this Operation Manual can be read independently and thus can be used for look-up purposes.

## 1.1 Terms of Guarantee

General sale and delivery terms of Tark Thermal Solutions apply. The buyer accepts these terms, at the latest when signing the contract of purchase.

The particular terms of guarantee and duration of guarantee of the unit in question can be taken from the contract documents as well as from the order confirmation.

Warranty claims and liability are excluded in case of one of the following situations:

- Use of the unit in an unintended way
- Inaccurate installation, putting into service, operation, repair or maintenance of the product by people that are not fully authorized
- Use of the product despite of defect, wrongly implemented or non-functional safety devices or protective gear
- Unauthorized or forbidden modifications by the user concerning the electrical equipment of the unit
- Unauthorized or forbidden modifications by the user concerning the mechanical structure of the unit
- Unauthorized or forbidden modifications by the user concerning the operating parameters
- Use of unauthorized tools
- Use of unauthorized operating supplies
- Exceedance of mandatory maintenance intervals
- Cases of disaster caused by foreign matter influence or act of nature beyond control

### NOTE

Any form of unintended use of the unit and any structural change caused by the user without prior authorization in written form by Tark Thermal Solutions will lead to the termination of warranty as well the termination of the declaration of conformation and will free Tark Thermal Solutions from product liability. This concern includes safety devices as well.

In case of authorized changes or when adding optional equipment, it is the sole responsibility of the customer to assure the accurate implementation of the safety devices required.

## 1.2 Contact Information

If you have questions with respect to this unit please use the contact information given below. Always communicate the following:

- Your name and address
- Name of contact at your address
- Product data as on identification plate: Type of unit, serial number and year of manufacture

Visit the website for contact details:

[www.tark-solutions.com](http://www.tark-solutions.com)

**Company contact:**

Tark Thermal Solutions

Prumyslová 497

463 12 Liberec

Czech Republic

## 2. Product Identification

### 2.1 Unit Specifications

Manufacturer	Tark Thermal Solutions
Type of product	Oil-air cooler
Type of unit	OL 4503
Article number	1264.00

*Table 1: Unit specifications*

### 2.2 Identification Plate

The identification plate is attached to the front side of the unit (see Fig. 1).



*Fig. 1: Position of identification plate*

1	Identification plate
---	----------------------

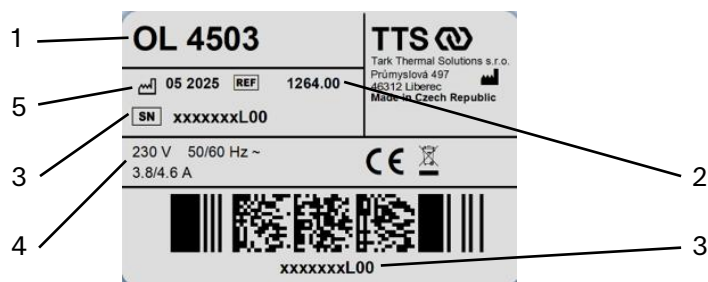

*Fig. 2: Unit specific identification plate*

1	Unit type	2	Part number
3	Serial number	4	Electrical specifications
5	Date of manufacture		

### 3.Safety Regulations

#### 3.1 Hazard classes

In this document safety instructions are using standardized representation and symbols. Depending on the probability of their incidence and the severances of consequences three hazard classes are used.



#### **DANGER**



**Reference to direct danger for humans.**

**Inobservance will lead to irreversible injuries or exitus.**



#### **CAUTION**

**Reference to noticeable danger for humans or possible damage to property.**



**Inobservance may lead to reversible injuries or to damage to property.**

#### 3.2 Safety Symbols



In this Operation Manual concrete safety instructions are given in order to point out unpreventable residual risks when operating the unit. These risks include danger for

- Human beings
- The unit and other equipment
- The environment

The safety symbols used in this manual are indicated below. The main reason for their use is to point the reader to the safety instruction given in the text field beside.

Symbol	Meaning
	Warning with respect to general danger or damage to property
	Warning with respect to electrical hazard

*Table 2: Warning Signs*

Symbol	Meaning
	This symbol indicates the requirement of wearing safety gloves
	This symbol indicates that disconnecting from mains is required.

### 3.3 Hints for Safe Operation

#### NOTE

##### **Conduct inspections on a regular time base!**

This will ensure that the appropriate measures will be carried out indeed.

The unit is operational save. It was built according to the existing state of technology.

Despite this the unit could cause hazards if it

- is used in a way it was not intended for
- is used improperly
- is operated under unsuitable conditions

### 3.4 Prevent Hazards

Hazards can be prevented by safety-conscious and anticipatory behavior of staff.

Everybody working with the unit should keep the following in mind:

- Make this Operation Manual available for everybody at the operational location of the unit in a complete and perfectly readable form!
- Use the unit exclusively for what it was intended!
- The unit must be operational and error free. Check the condition of the unit before working with it and within a regular time frame!
- Make sure that nobody can injure himself by any part of the unit!
- Any disruption or recognizable change concerning the unit should be reported to the responsible person!
- Stick to the accident prevention regulations as well as any regional regulations!

### 3.5 Hints Regarding the Electrical Equipment



#### **DANGER**



##### **Danger to life through electrical shock when working on the electrical equipment of the unit!**

- Switch off the unit before starting your work!
- Disconnect the unit from mains by pulling the mains plug!
- Verify that the installation is dead (volt-free)!
- Carry out earthing or short circuiting!

When working on electrical installations the following principles should be observed:

- Works on the electrical installations may only be accomplished by qualified electrical staff!
- When connecting electrical equipment to mains regional regulations must be observed. Be aware of the information in the wiring diagram!
- The unit is powered by electricity. Electrical shock hazard exists, if the electrical installations are defective or the insulation fails during operation.
- When switched off the unit is not disconnected from mains. This is only the case when the mains plug is pulled.
- Any changes regarding the control elements of the unit can have an influence on the safe operation. All intended changes must be authorized by the manufacturer.

- After the implementation of a change the safeguard operations must be verified.
- No unauthorized changes on the unit are allowed. All intended changes must be authorized by the manufacturer.

### 3.6 Environmental Issues

Environmentally conscious and anticipatory behavior of staff avoids environmentally hazardous impacts.

The following principles apply for environmentally conscious behavior:

- Environmentally hazardous substances must not get into the ground or the drains. They should be kept in appropriate containers.
- Environmentally hazardous substances must be fed to utilization or disposal according to regional regulations.

When dealing with operating supplies always keep aware of the safety data sheet of the corresponding manufacturer.

### 3.7 Protective Clothing

When doing a job that leads to contact of the skin with the coolant (e.g. filling-up of the coolant container):

	Wear safety gloves made of PVC, neoprene or nitrile rubber
--	--

### 3.8 Safety Equipment

#### NOTE

The safety equipment listed below must be integrated in the local control environment by the customer, unless otherwise noted. These works must be carried out only by trained experts. All required information can be taken from the wiring diagram shown in the addendum.

Safety equipment must not be modified, removed or taken out of operation. All parts of the safety equipment must be accessible at all times.

### 3.9 Safety and Signaling Equipment included in the Unit

The unit is equipped with safety equipment at critical spots (see Fig. 3)

- The water throughput is controlled by a flow control device that must be integrated in the potential-free safety circuit of the device to be cooled.
- The maximum temperature of the cooling circuit is controlled by a non-variable thermostat with an opener contact that must be integrated into the safety circuit of the device to be cooled.
- The maximum pump pressure is limited by a safety valve that by-passes the liquid stream when the pressure pre-set is exceeded.

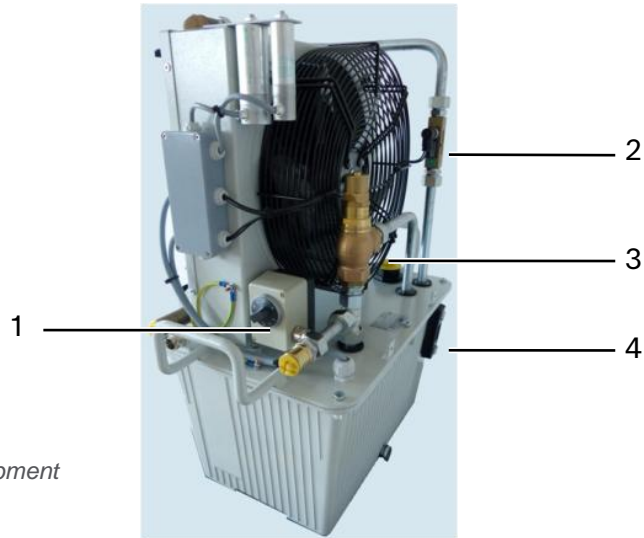

Fig. 3: Safety equipment

1	Thermostat	2	Flow control device (flow switch)
3	Angle-type safety valve	4	Inspection glass, level indicator

### 3.10 Guards

Direct access to hazardous parts or areas of the unit is restricted by the unit cover. The cover may only be removed for the purpose of maintenance or repair works and shall be replaced prior to taking the unit back to operation. The cover is fixed by four screws which can be unscrewed using a metric AF10 wrench.

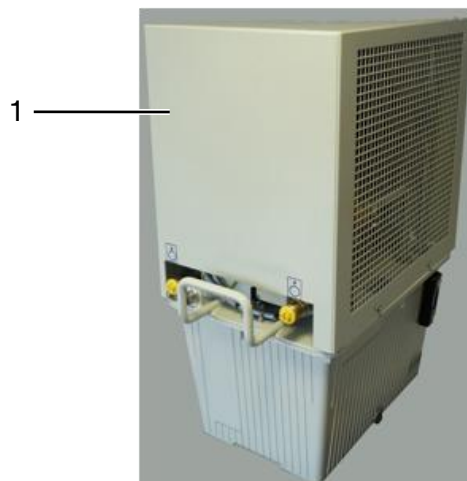

Fig. 4: Guards

1	Unit cover
---	------------

### 3.11 Caution Labels

Danger spots on the unit are indicated based on requirements set by Directive 92/58/EEC on the minimum requirements for the provision of safety and/or health signs at work.

Caution labels on the unit must be easily readable at all times. Illegible caution labels must be exchanged without delay.

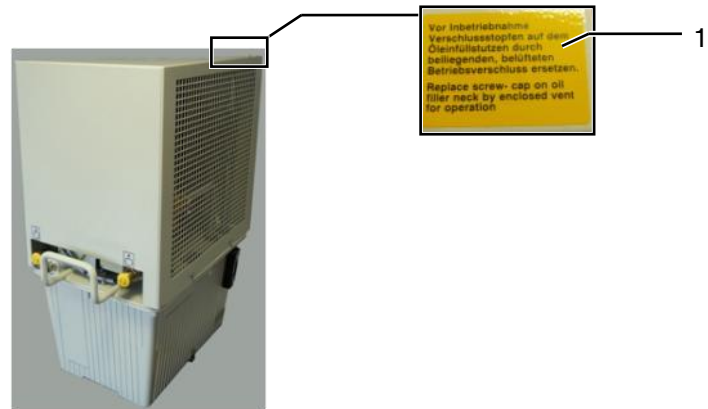

*Fig. 5: Caution labels on the unit*

1	Hint for using the correct cap on oil filler		
---	--	--	--

### 3.12 In Case of Accidents

Should you or another person be injured when working with the unit:

- Stay calm!
- Render first aid!
- Call the company first-aider without exception!

#### 3.12.1 First aid at accidents with oil

The unit employs oil as a coolant in a closed-loop configuration. In case of damage oil can leak from the circuit and cause hazards.

- Long term or repeated contact with skin without appropriate cleaning may obstruct the skin pores and may lead to irregularities as oil acne or folliculitis.

When exposed to oil always observe the safety data sheet of the manufacturer

## 4. Product Description

### 4.1 Intended Use

The oil-air cooler OL 4503 is used for the cooling of an oil circuit. Oil circulates between the cooling unit and the device to be cooled. The oil is re-cooled by an air-cooled heat exchanger. The maximum cooling capacity depends on the ambient air temperature (see [page 16](#)).

The unit is exclusively intended for use in industrial and commercial environments.

The intended use also includes the observance and following of all hints given in this Operation Manual.

### 4.2 Use not in Conformance with the Intended Use

Operation of the unit under improper operational conditions is not allowed, since otherwise the operation safety cannot be granted.

When using the unit in a way not compliant with the intended use, hazardous situations may occur.

Operation of the unit is not allowed under the following conditions:

- The unit is used for a purpose other than the one it is intended for.
- The unit or parts of it are damaged, the electrical installation is not correct or the insulation is broken.
- Protective or safety equipment is not functional or defect, improperly installed or missing.
- The unit is not working properly.
- Controlling devices were modified in a way that is not permitted.
- Operational parameters were changed in a way that is not permitted.
- Operation in areas exposed to explosion hazards
- Operation with cooling media not according to specification
- Use of unauthorized tools
- Exceedance of the compulsory maintenance intervals

#### NOTE

The manufacturer is not liable for damage occurring when using the unit in a way it was not intended for.

When using the unit in a way it was not intended for, the manufacturer's warranty given by Tark Thermal Solutions will expire.

### 4.3 Unit Components

Additional information can be retrieved from the flow scheme shown in the addendum. The unit consists of the following main components:

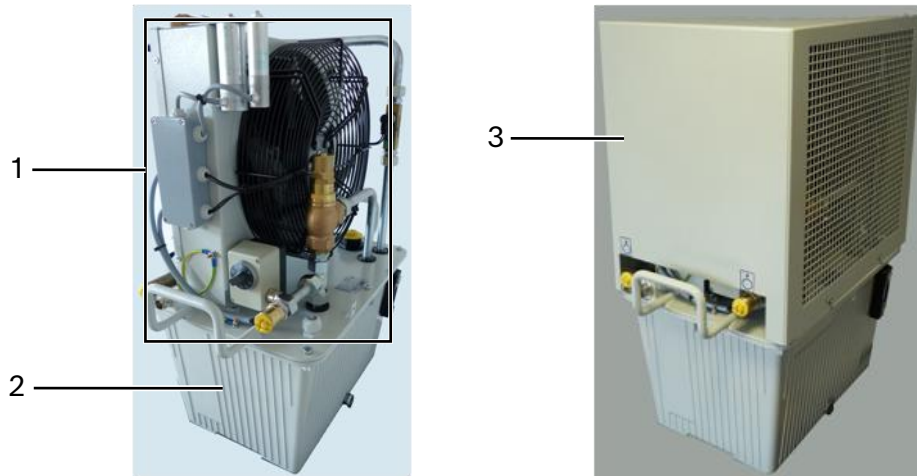
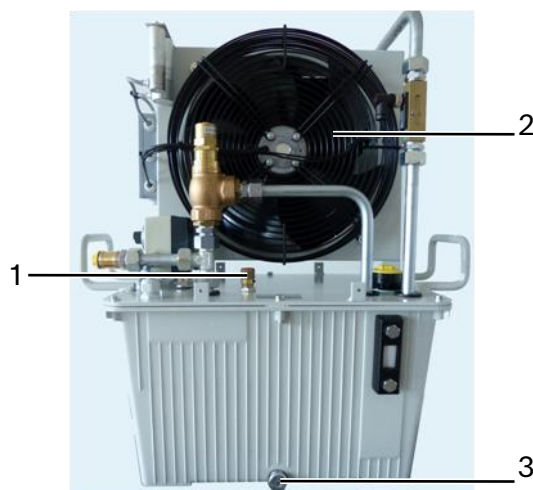

*Fig. 6: Main components*

1	Cooling circuit	2	Coolant container
3	Sheet-metal hood		

### 4.4 Cooling Circuit

In the cooling circuit the coolant (i.e. the oil) is driven by the pump to the device that is to be cooled and back via the return flow. The heat is dissipated into the ambient air by an air-cooled heat exchanger. Exceedance of the maximum pump pressure is prevented by a bypass circuit. The oil temperature is controlled by an electronic thermostat. Oil throughput is controlled by a flow control device.



*Fig. 7: Main components*

1	Stop valve	2	Fan
3	Oil drain screw		

## 4.5 Specifications

### Dimensions and weight

Length:	650 mm
Width:	350 mm
Height:	750 mm
Weight:	49.6 kg (empty)
Coolant capacity:	23 liters (Shell Diala S4-ZXIG)

*Table 4: Dimensions and weight*

### Performance data

Cooling capacity:	4500 Watts at 22.8 K difference between the oil outlet temperature and the ambient air temperature
Pump capacity:	> 20 lpm at 4.7 bar
Mains voltage:	230 VAC $\pm$ 10% 50/60 Hz
Power input:	785 Watts (Pmax; 230 V; 50 Hz) 1058 Watts (Pmax; 230 V; 60 Hz)

*Table 5: Performance data*

### Environmental conditions

Operating temperature:	-10°C ... +40°C
Storage temperature:	-25°C ... +70°C
Relative humidity:	20% ... 90%

*Table 6: Environmental conditions*

### Settings

Flow control device	14.0 $\pm$ 0.3 lpm
Thermostat	55 $\pm$ 3 °C
Maximum pressure	9.0 +0.5/-0.2 bar

*Table 7: Settings*

## 4.6 Setting-up Requirements

### Installation Location

- The location must be even.
- When choosing the installation location, the following must be kept in mind: the air flow of the cooling air must not be restricted, forward and back flow connections must be easily accessible and all tubes must be installed without sharp bends.

### Environmental Conditions



#### CAUTION

**Risk of damage through unsuitable environmental conditions.**

**Damage to property and corrosion damage may result and are not covered by manufacturer's liability.**

- The unit is only authorized for use in indoor environments.
- The unit must not be stored or operated in aggressive, humid environments.
- The unit must not be stored or operated outdoor.

Pay attention to the environmental conditions as given in the specifications on page 16.

## 4.7 Infrastructure

The following infrastructure is required for connecting the unit:

Parameter	Rated value
Operating voltage	230VAC

*Table 8: Required infrastructure*

## 5. Transport

### 5.1 Safety Indications for Transportation and Setting-up



#### CAUTION

**Risk of injury by lifting the unit!**

**The weight of the unit is more than 50 kg.**

- Do not lift the unit manually!
- Always use proper auxiliary means such as a forklift or a jack lift!

### 5.2 Transportation of the Unit

The unit is delivered wrapped in foil on a transportable pallet. Leave the unit on the pallet until bringing it into service. Use a forklift or jack lift for transportation to the installation location.



#### CAUTION

**Risk of damage by improper transportation!**

- Transport the unit in upright position.
- Do not tilt the unit or expose it to impacts.

### 5.3 Unpacking

Remove the foil before setting up the unit!

Inspect the unit regarding:

- Damage caused by transportation
- Completeness of delivery

Lift the unit with a forklift or jack lift off the transportable pallet.

Dispose of the packaging material in accordance with regional regulations.

#### NOTE

Tark Thermal Solutions advises keeping the transportable pallet for later transportation of the unit.

## 6. Initial Operation

### 6.1 Safety Indications Related to Initial Operation



#### CAUTION

**Danger of malfunction caused by faulty connections during initial operation!**

Before switching on the unit make sure that

- All safety equipment of the unit is implemented and functional
- All connections were properly made
- Nobody is endangered by the start-up of the unit.

Please follow the rules in chapter Safety Regulations on page 9.

### 6.2 Setting to Work

#### Placement

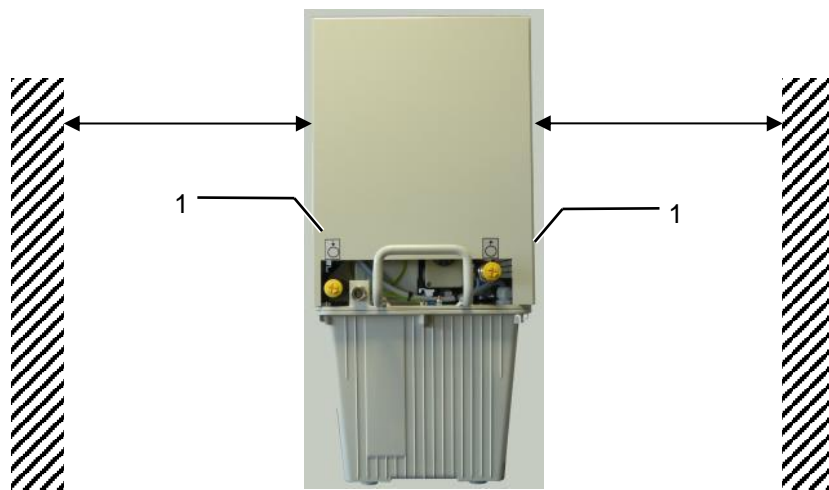

*Fig. 8: Minimum clearance for air entrance and air exit*

1	Ventilation grid
---	------------------

- 1) Move the unit to its installation location as mentioned in chapter 4.
- 2) Place the unit in a way that air entrance and air exit are not obstructed. Wall clearance must not be less than 0.5 m, otherwise cooling capacity may be restricted.

#### NOTE

In case of storage of the unit at temperatures lower than 5°C or higher than 40°C for longer periods please wait 3 hours prior to initial operation to allow for temperature adjustment.

### 6.3 Cooling Circuit Connection and Filling



#### CAUTION

**Risk of damage by using improper cooling hoses!**

**This may lead to damage to persons, damage to the unit or corrosion damage.**

- When choosing cooling hoses pay attention to sufficient burst strength and compatibility with coolant!
- Only use cooling hoses without any signs of damage!

The cooling hoses are connected to the unit by means of screwed hose nipples.

Oil inlet and oil outlet are indicated with respective symbols.

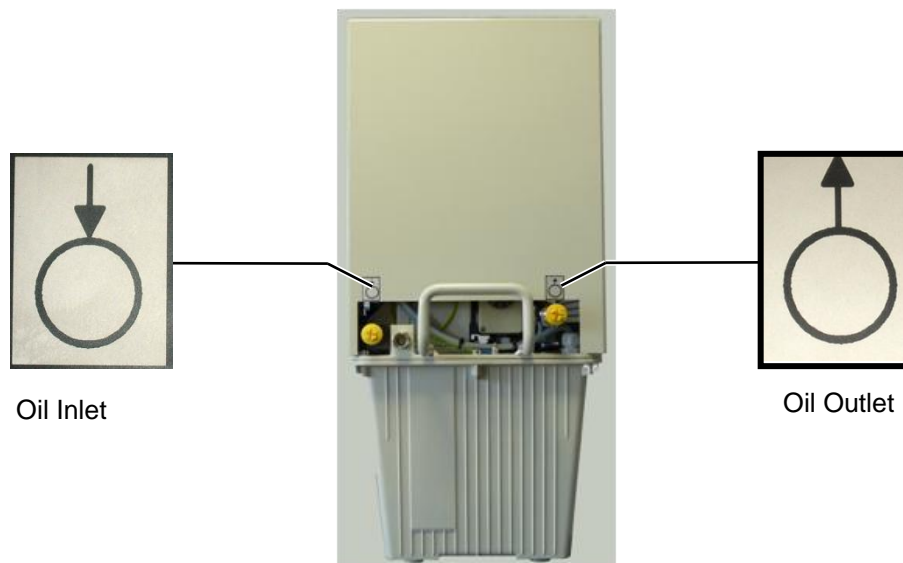

*Fig 9: Labelling of oil inlet and oil outlet*

#### NOTE

When operating the unit make sure only to use the operation coolant container cap. This cap allows for pressure equilibrium in the cooling system (breathing). Save the transportation cap for later transportation purposes (e.g. when sending the unit back for repair).

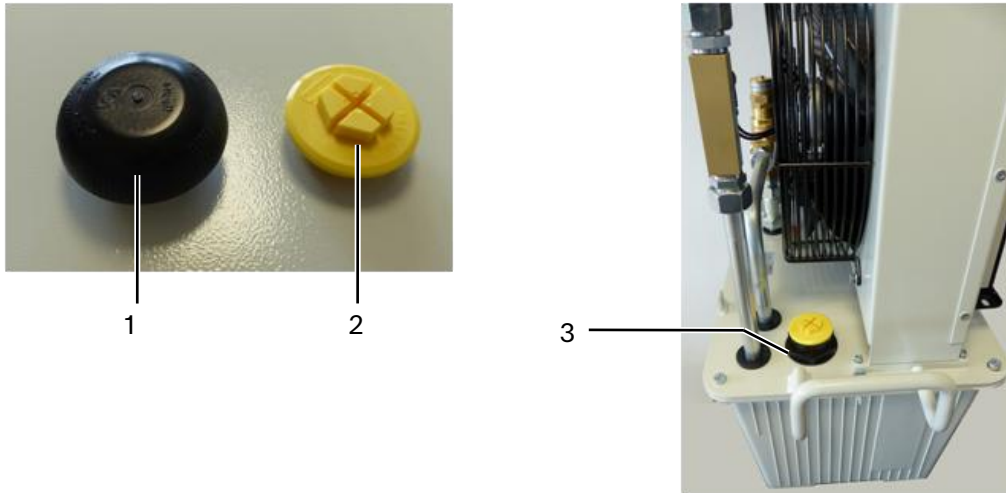

**Fig. 10:** Operation cap, transportation cap, filler plug of coolant container

1	Operation cap	2	Transportation cap
3	Filler plug of coolant container		

- 1) Unscrew the four screws of the unit cover using a metric AF10 wrench and remove the cover.
- 2) Remove the caps from the hose nipples of oil inlet and oil outlet.
- 3) Connect a hose to the hose nipples for oil inlet and oil outlet and secure it with a hose clamp, respectively.
- 4) Connect the hoses to the corresponding nipples of the device to be cooled.

#### NOTE

When connecting the cooling hoses pay attention to flow direction. Follow the documentation released by the manufacturer of the device to be cooled.

- 5) Remove the transportation cap on the coolant container using an appropriate wrench.
- 6) Fill the coolant container with oil up to a filling level indicated roughly in the center of the inspection glass.  
Use a funnel in order not to moisten any current-carrying components with oil
- 7) Close the coolant container using the operation cap supplied on delivery.

## 6.4 Electrical Connections



### DANGER



#### **Danger to life through electrical shock when working on the electrical equipment of the unit!**

- Switch off the unit before starting your work!
- Disconnect the unit from mains by pulling the mains plug!
- Verify that the installation is dead (volt-free)!
- Carry out earthing or short circuiting!



### CAUTION

#### **Risk of damage through improper connections!**

Improper integration of the unit into the safety circuit of the device to be cooled will lead to the inoperativeness of the safety equipment listed in chapter 2.

- All connections required must be incorporated according to the wiring diagram shown in the addendum.
- Ensure that all connected safety equipment is properly functioning!
- All works should be carried out only by expert staff

### NOTE

The unit is delivered without a mains cable. The electrical connection as well as the integration into the safety circuit of the device to be cooled are the customer's responsibility and must be accomplished by expert staff.

Required information can be drawn from the specifications listed on page 16 and the wiring diagram in the addendum.

---

After implementing the mains cable connect the unit to mains by inserting the mains plug.

## 6.5 Carrying out Setting to Work



### CAUTION

#### **Lack of coolant may destroy the pump!**

- Operate the unit only when the filling level of the coolant container is correct!
- Check the filling level of the coolant container regularly!

After connecting the cooling circuit, filling the coolant container and finishing the electrical connection

follow the steps below for the setting-to-work of the unit:

- 1) Open the stop valve.
- 2) Let the unit run for about 1 minute in order to de-aerate the pump.
- 3) Switch off the unit.
- 4) Close the stop valve.
- 5) Let the unit run for about 10 minutes in order to fill and de-aerate the cooling circuit.
- 6) Switch off the unit.

- 7) Check the filling level using the inspection glass. Fill up oil, if required, until a liquid level in the center of the inspection glass. Use a funnel in order not to moisten any current-carrying components with oil.
- 8) Remount the unit cover.



## **DANGER**



### **Danger to life by electrical shock caused by improperly mounted grounding washer!**

- Mount the grounding washer at the position of one of the four screws securing the unit cover!
- Make sure that the screws are properly tightened!

**This is to make sure that the grounding washer cannot get loose by vibrations during operation which could lead to the situation of the unit cover carrying current.**

- 9) Switch on the unit again and check the compliance with the operational parameters.

The unit is ready for use.

## **6.6 Daily Start-up**

Switch on the unit about 1 minute prior to using the equipment that is to be cooled.

## **6.7 Setting to work after Storage**

Setting to work after storage will have to follow the same procedures as required for initial operation (see chapter 6).

## 7. Controlling the Unit

The unit is controlled using the controls of the equipment that is to be cooled.

All alarm and error signaling is only indicated on the control panel of the equipment that is to be cooled.

### 7.1 Safety Indications for Controlling the Unit



#### CAUTION

##### Lack of coolant may destroy the pump!

- Operate the unit only when the oil filling indication on the coolant container is correct!
- Check the oil filling indication regularly!

Also pay attention to the hints given in the chapter Safety indications on page 9.

### 7.2 Switching on the Unit

- The unit is ready for switching on.
  - 1) Switch on the unit about 1 minute prior to operation of the device to be cooled using the appropriate control of that device.
  - 2) Check the compliance with the operational data according to the specifications listed on page 16.
- ⇒ The unit is running.

### 7.3 Switching off the Unit

- 1) Switch off the unit using the control of the device to be cooled.
  - 2) Close all valves that may exist in the extension of the hoses running to and from the unit.
- ⇒ The unit is out of operation.

## 7.4 Settings

The angle-type safety valve and the thermostat are set to the specified values by the manufacturer. Should any modification be required, please follow the steps indicated below.

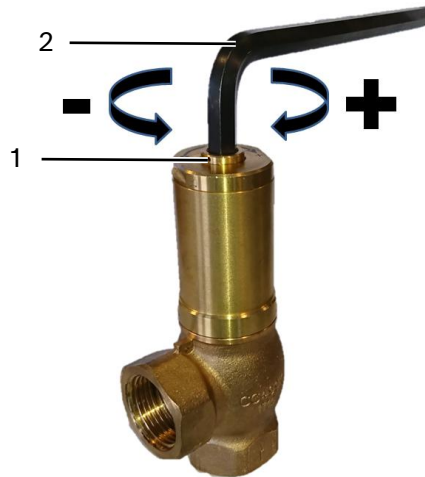

Fig 11: Angle-type safety valve

1	Adjusting screw	2	Hexagonal wrench key No 10
---	-----------------	---	----------------------------

## 7.5 Pressure Setting on the Angle-type Safety Valve

### NOTE

A small amount of oil may leak from the valve.

- The unit is switched off.
  - 1) Carry out pressure adjustment with hexagonal wrench key.
  - 2) Turning clockwise increases pressure, turning anticlockwise decreases pressure.
  - 3) The valves can be set when backpressure prevails or when medium is flowing through the valve.
  - 4) The setting can be secured by means of a seal.
  - 5) Check the maximum pressure again and repeat the setting, if necessary.
  
- The maximum pressure is now set.

## 7.6 Setting the Thermostat

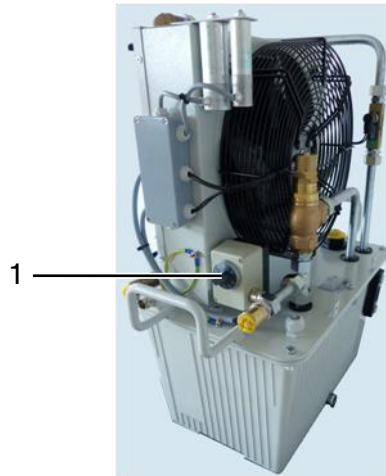

*Fig 12: Thermostat*

1	Knob of thermostat
---	--------------------

### **Increase the temperature setpoint**

- 1) Turn the knob clockwise.
- ⇒ The switch-off temperature is set to a higher value.

### **Decrease the temperature setpoint**

- 1) Turn the knob counter-clockwise.
- ⇒ The switch-off temperature is set to a lower value.

## 8. Disruptions

### 8.1 Disruption in Operation

The most common reason for disrupt operation of the unit is improper maintenance. Maintenance should be carried out regularly according to the maintenance intervals defined in chapter 9.

In case of disruption start with checking the following:

- Fan polluted or blocked?
- Coolant polluted?
- Low coolant contents because of leakage, evaporation or an extended cooling circuit with long hoses?

More help can be found in the following paragraph.

In case you do not succeed in identifying the problem cause by means of this manual please contact the service department of Tark Thermal Solutions.

### 8.2 Troubleshooting

For troubleshooting you may rely on the following:

- Alarm signaling within the safety circuit of the device to be cooled
- Wiring diagram
- Flow scheme
- Troubleshooting table given below

Problem	Possible reason	Countermeasure
The unit does not start	Mains cable plugged in?	Insert mains plug→ page 22
The unit is running, but cooling capacity is not available or too low	External hoses sharply bent?	Pay attention to smooth bends, when hoses are connected
	Unit properly located?	Clearance to walls not less than 0.5 m→ page 18
	Coolant hoses connected?	Connect hoses considering flow direction→ page 20
	Is there flow in cooling circuit?	Flow is signaled potential-free by the safety equipment of the unit and can be visualized in
	Fan turning?	Cover the ventilation grid next to the fan with a sheet of paper. If the paper is sucked and hold by the airflow, the fan works properly.
	Ambient temperature too high?	Check specifications → page 16
Noisy unit	Contents in coolant container low	Refill coolant

Table 9: Troubleshooting list

## 9. Maintenance and Cleaning

Diligent maintenance is the prime factor for assuring an error-free and efficient operation of the unit. Operating personnel can perform these tasks when properly trained.

### 9.1 Maintenance Schedule

Device	Activity	Interval	Criteria	Tools	Performer
Heat Exchanger	Clean	Minimum weekly (if required, daily)	Plate fins and ventilation grids not polluted	AF10 wrench, compressed-air, vacuum cleaner	Operating personnel
Coolant container	Check filling	Weekly	Coolant indication in the center of inspection glass	Funnel, measuring cup	Operating personnel
Coolant quality	Inspect visually	Weekly	Absence of cloudiness or floating particles	Inspection glass on coolant container	Operating personnel

Table 10: Maintenance schedule

### 9.2 Cleaning of Heat Exchanger

Cooling capacity is reduced to a large extent, if the heat exchanger is polluted. The heat exchanger must be checked for pollution regularly and be cleaned, if required.

For cleaning the heat exchanger follow these steps:

- 2) Switch off the unit.
- 3) Unscrew the four screws holding the unit cover with a AF10 wrench and remove the cover.
- 4) Clean the heat exchanger using compressed air opposite to the direction of air entrance into the unit (i.e. from the inside out).
- 5) Remove any pollution from the ventilation grids using a vacuum cleaner.
- 6) Remount the unit cover.

⇒ The unit is ready for operation.

### 9.3 Refilling of Coolant

Since the cooling circuit is an open circuit, evaporation of coolant may occur. Thus the filling level of the coolant container has to be checked regularly, and coolant might have to be refilled as described in chapter 6 on page 20.

### 9.4 Cleaning of Unit Casing



#### CAUTION

**Risk of damage through use of improper cleansing material. When using aggressive or abrasive cleaning agents corrosion may occur as result of a damaged paint film.**

- For cleaning the unit casing only use mild cleaning agents (e.g. dish washing detergents)!
- Use clean and lint free cloth for cleaning!

Regularly remove dirt from the casing of the unit to prevent corrosion damage and clogging of the air grids. Pay attention that all the plates at the unit are always clean and legible.

## 10. Repair

### NOTE

Do not carry out any repair work on the unit. Send the unit back to the Tark Thermal Solutions service department (for contact see [page 7](#)).

---

## 11. Dismounting, Disposal, Storage

### 11.1 Temporary Placing out of Operation

For placing the unit out of operation for maintenance or repair follows the steps below:

- 3) Switch off the unit.
- 4) Close all valves that may be incorporated in the cooling circuit.
- 5) Disconnect all hoses to and from the unit.
- 6) Place a collection container of sufficient volume (23 liters minimum) close to the drain screw.
- 7) Loosen the drain screw with a 10 mm Allen key and remove it.
- 8) Let the coolant container run empty into the collection container. To empty the coolant container completely the unit must be tilted.

#### NOTE

The coolant has to be collected and disposed of according to applicable regulations.

- 7) Re-attach the drain screw and clean the unit.

⇒ The unit is placed out of operation.

### 11.2 Re-packaging of the unit

In order to prevent spilling of residual coolant from the coolant container during transport the transport cap must be attached.

- The unit has been switched off, emptied (see chapter 11) and the unit cover has been removed.
- 1) Remove the operation cap from the coolant container.
  - 2) Attach the transport cap.
  - 3) Remount the unit cover.
  - 4) Put the protection caps on the hose clamps.
  - 5) Lift the unit with a forklift or jack lift and place the transportable pallet under it.
  - 6) Enclose the unit including the transportable pallet with shrinking foil and shrink the foil tight.
- ⇒ The unit is ready for transportation.

### 11.3 Storing the Unit

The storage area must be even and the unit should not stand on an edge or other obstructive object.

The environmental conditions for storage of the unit or parts of it can be found in the specification paragraph on page 16.

### 11.4 Disposal

The unit was manufactured mainly from recyclable material.

Make sure the components of the unit end up at a qualified company for disposal and recycling.

Contact Tark Thermal Solutions for take back of end-of-life units (see company contact on page 7) or ask a company destined for disposal and recycling.

## **11.5 Disposal of Operating Materials**

The operating materials of the unit can be hazardous to the environment and to health.

Make sure the operating materials are disposed of or recycled according to local regulations.

Also, the safety specifications of the coolant manufacturer must be obeyed.

## **11.6 Return of the unit to Tark Thermal Solutions**

### **NOTE**

#### **Declaration of decontamination**

Before re-shipment of the unit a declaration of decontamination must be sent to Tark Thermal Solutions.

---

## 12. Wear Parts and Spare Parts

Spare parts must comply with the technical specifications defined by Tark Thermal Solutions. Original Tark Thermal Solutions parts are subject to strict obligations and fulfill these requirements.

Tark Thermal Solutions does not provide warranty service in case of damages caused by the use of spare parts made by manufacturers other than Tark Thermal Solutions.

### NOTE

#### Identification data concerning the unit and spare parts

The type of unit and the article number can be found on the identification plate of the unit. The corresponding numbers shown in drawings 12 and 13 as well as the part description are listed in the spare part list (table 11).

Please direct your inquiries and orders to Tark Thermal Solutions (contact see page 7) with the following detailed information

- Type of unit
- Article number
- Serial number
- Part description
- Quantity
- Shipping details

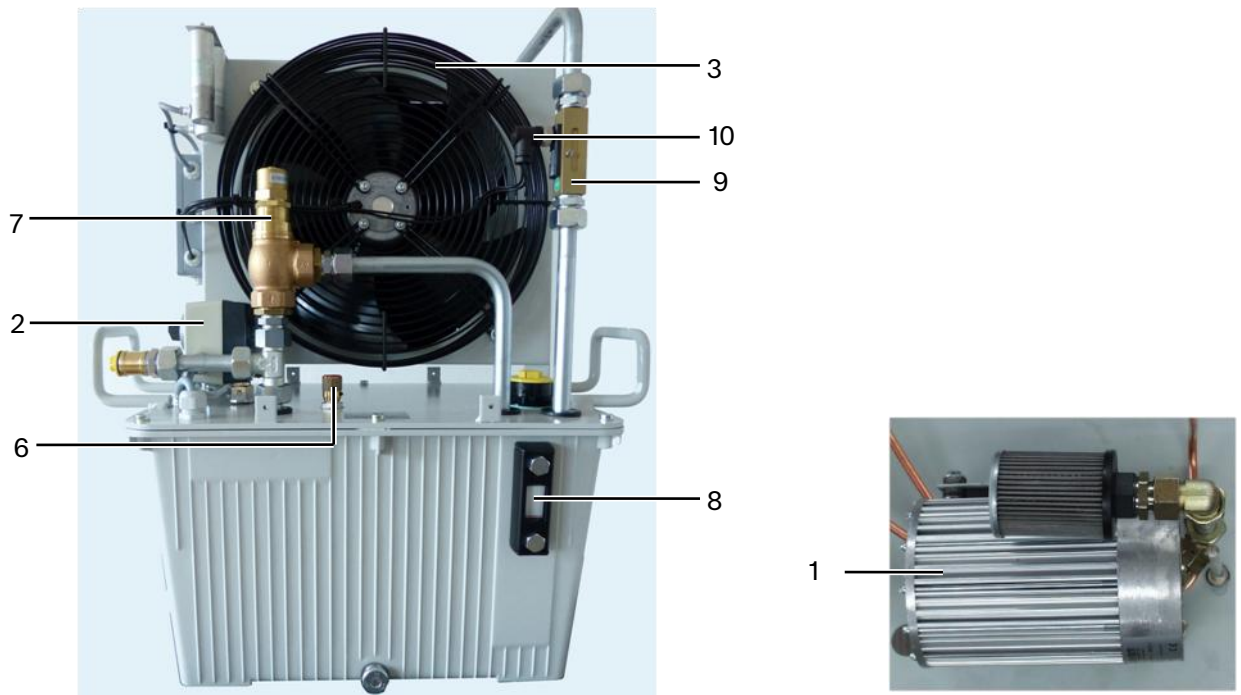
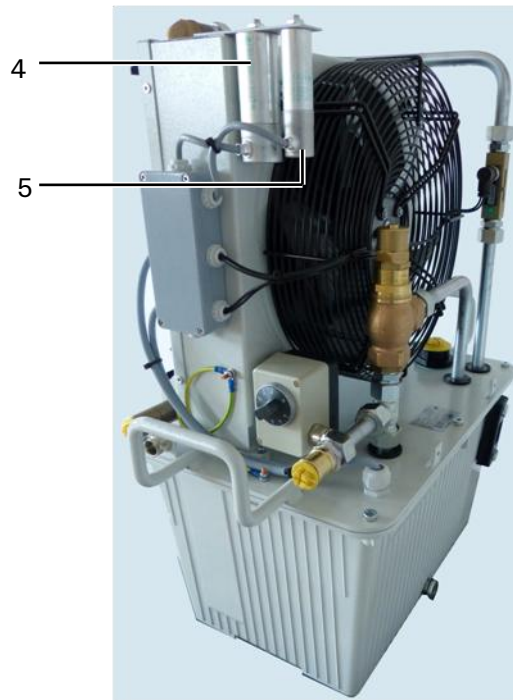

Fig 13: Spare part overview part 1



*Fig 14: Spare part overview part 2*

Pos.	Qty	Description	Article No.
1	1	Spare Pump 230V,50/60H,KA1-26-230-2	2066.00
2	1	Thermostat AMFS-13	2040.00
3	1	Axial fan S4E 330-AP 18-31	2064.00
4	1	Starter capacitor for fan	2058.00
5	1	Starter capacitor for pump	2045.00
6	1	Stop valve 1/4"	2050.00
7	1	Angle-type safety valve	2042.00
8	1	Inspection glass	2055.00
9	1	Flow switch	2065.00
10	1	Control head for flow switch	2056.00

*Table 11: Spare parts*

## 13. Addendum

### Performance Chart

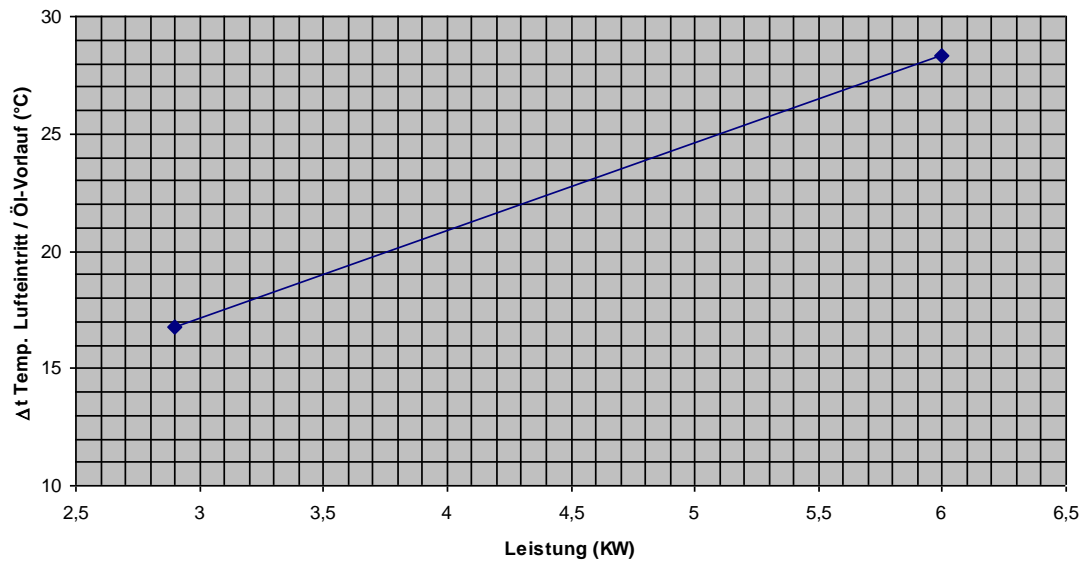

*Cooling capacity versus difference between entering air and supplied coolant temperatures*

# Flow Scheme

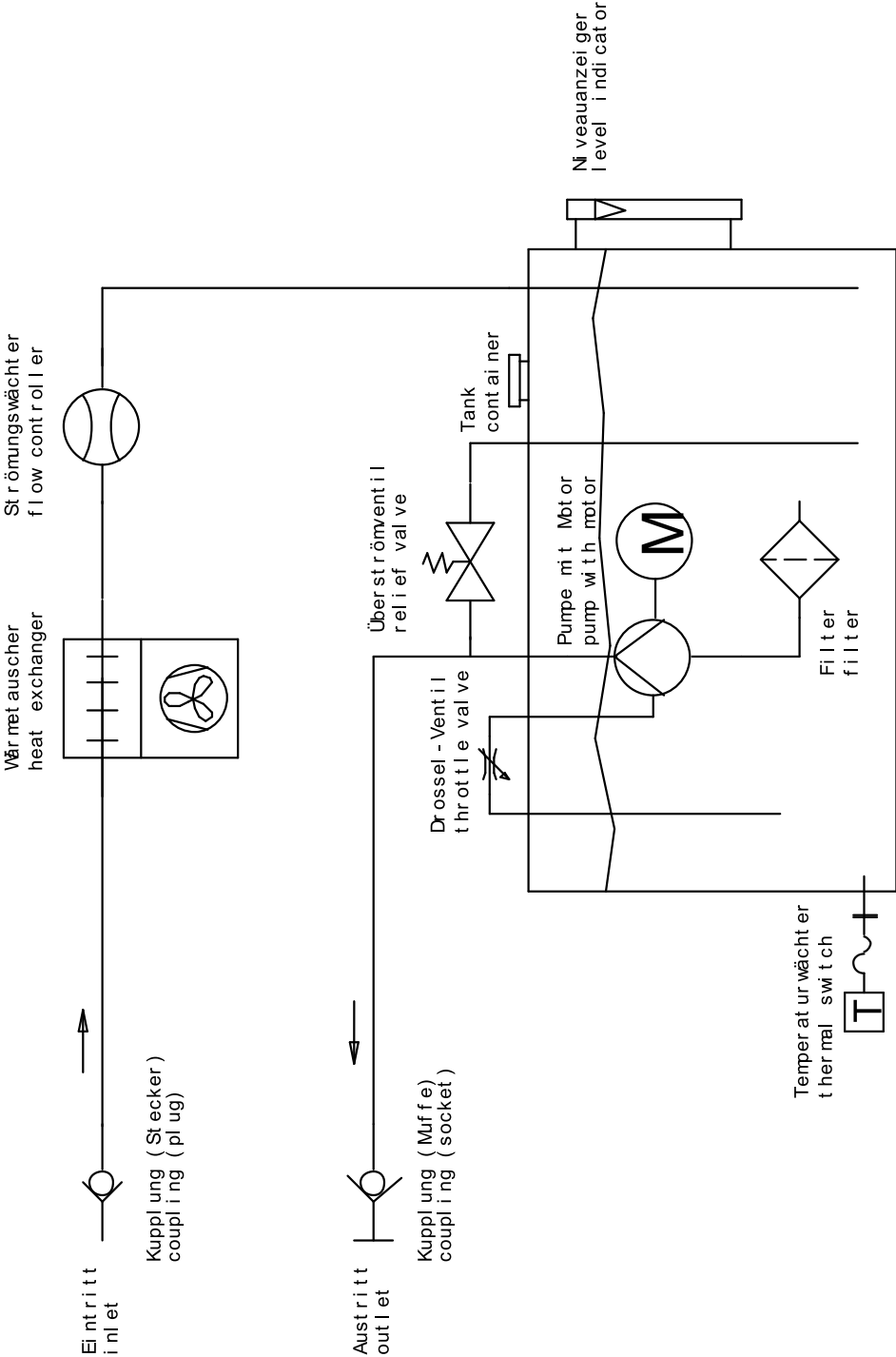

## Wiring Diagram

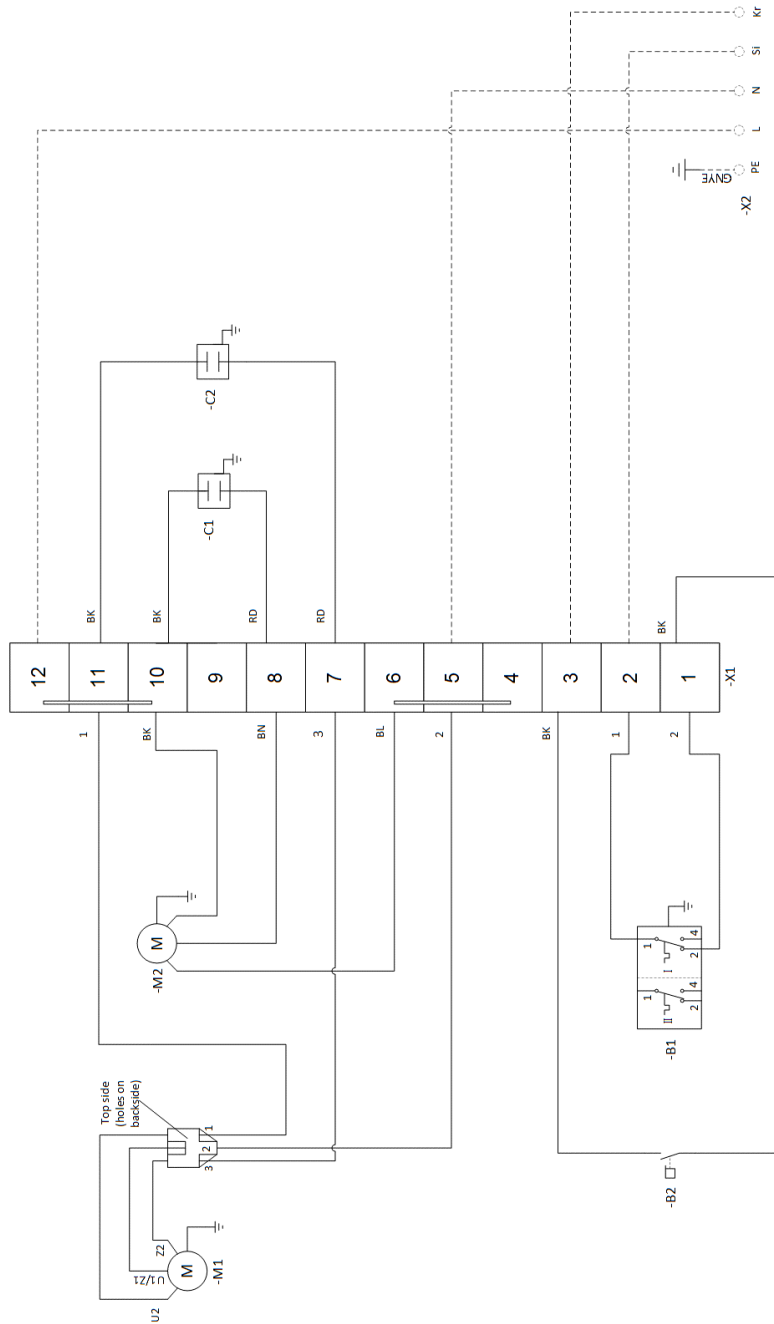

Item	Description
B1	Thermostat
B2	Flow switch
C1	Starter capacitor for fan
C2	Starter capacitor for pump
M1	Pump
M2	Fan
X1	Electrical box terminals
X2	Unit external cable connection (Not included in the unit)